

# **Holman**<sup>®</sup> **PROVEYOR** **MULTI-PURPOSE OVEN**

MODEL  
314HX, 318HX Series

## **Installation and Operation Instructions**

2M-HG0105 Rev. B 9/15/05

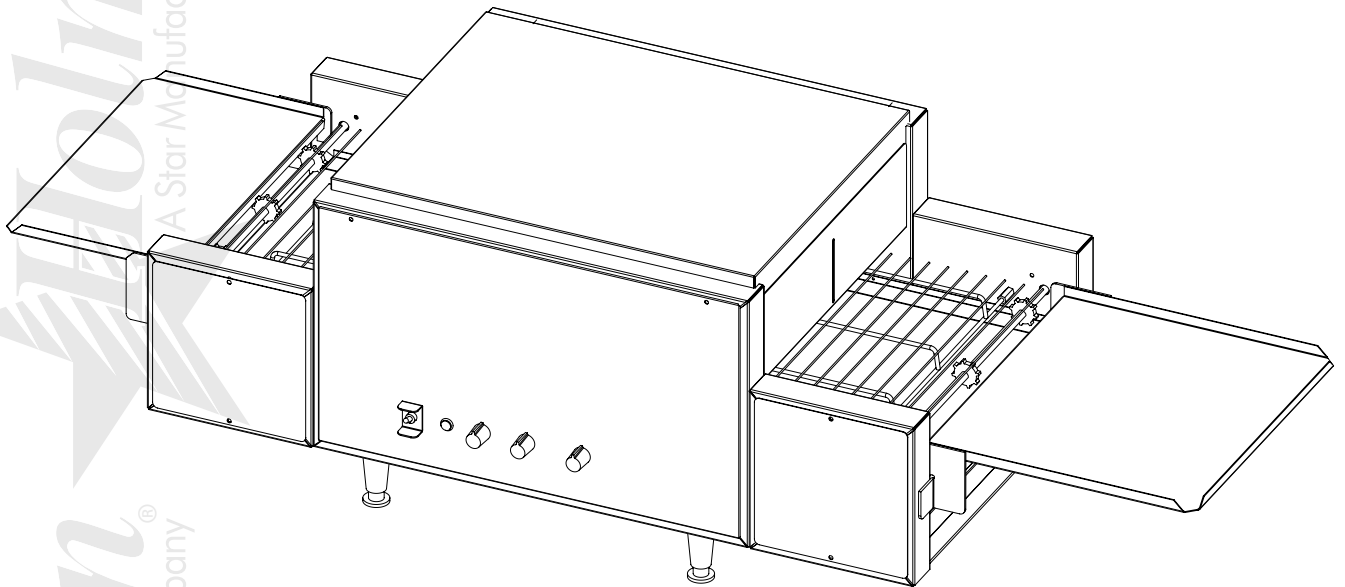

9G-314HX



## SAFETY SYMBOL



These symbols are intended to alert the user to the presence of important operating and maintenance instructions in the manual accompanying the appliance.

---

## RETAIN THIS MANUAL FOR FUTURE REFERENCE NOTICE

Using any part other than genuine Star factory supplied parts relieves the manufacturer of all liability.

Star reserves the right to change specifications and product design without notice. Such revisions do not entitle the buyer to corresponding changes, improvements, additions or replacements for previously purchased equipment.

Due to periodic changes in designs, methods, procedures, policies and regulations, the specifications contained in this sheet are subject to change without notice. While Star Manufacturing exercises good faith efforts to provide information that is accurate, we are not responsible for errors or omissions in information provided or conclusions reached as a result of using the specifications. By using the information provided, the user assumes all risks in connection with such use.

## MAINTENANCE AND REPAIRS

Contact your local authorized service agent for service or required maintenance. Please record the model number, serial number, voltage and purchase date in the area below and have it ready when you call to ensure a faster service.

Model No. \_\_\_\_\_

Serial No. \_\_\_\_\_

Voltage \_\_\_\_\_

Purchase Date \_\_\_\_\_

### Authorized Service Agent

Reference the listing provided with the unit

or

for an updated listing go to:

**Website:** [www.star-mfg.com](http://www.star-mfg.com)  
**E-mail** [Service@star-mfg.com](mailto:Service@star-mfg.com)  
**Telephone:** (800) 807-9054 Local (314) 781-2777

### The Star Service Help Desk

**Business Hours:** 8:00 am to 4:30 p.m. Central Standard Time

**Telephone:** (800) 807-9054 Local (314) 781-2777

**Fax:** (800) 396-2677 Local (314) 781-2714

**E-mail** [Parts@star-mfg.com](mailto:Parts@star-mfg.com)  
[Service@star-mfg.com](mailto:Service@star-mfg.com)  
[Warranty@star-mfg.com](mailto:Warranty@star-mfg.com)

**Website:** [www.star-mfg.com](http://www.star-mfg.com)

**Mailing Address:** Star Manufacturing International Inc.  
10 Sunnen Drive  
St. Louis, MO 63143  
U.S.A

## TABLE OF CONTENTS

	PAGE
Maintenance and Repairs	2
Star Contact information	2
Specifications	3
General Information Data	4
Inspection & Assembly	4
Assembly and Installation	4
Heating Elements	5
Cooling System	5
Final Check	5
Electrical Connection	5
Stacking Ovens	6
Daily Operation	7
Oven Components	7
Operating Hints & Safety	7
Cleaning	8
Maintenance Procedures	11
Troubleshooting Guide	13
Limited Equipment Warranty	14
Wiring Diagram	15-18
Exploded View Illustration	20
Parts List 314HX	21
Parts List 318HX	22
Control Box Configuration	23

## SPECIFICATIONS

---

### 9G-314HX

Rating/Connection: 5,400 Watts  
NEMA Plug: 6-30P, 3 Phase: 6-30P  
Electrical Supply: Separate service per oven - 8.7 Amp, 380/220 VAC, 3 phase, 50 Hz  
Approximate Weight (314HX Oven with Legs): Installed - 86 Lbs (40 kg), Shipping - 115 Lbs (52 kg)  
Dimensions: Width: 60" (152.4 cm) - Oven with Shelves  
Depth: 21 1/4" (54 cm)  
Height: 16 1/8" (40 cm) - Single Oven with Legs

---

### 9G-318HX

Rating/Connection: 6,200 Watts  
NEMA Plug: 6-30P, 3 Phase: 6-30P  
Electrical Supply: Separate service per oven - 9.9 Amp, 380/220 VAC, 3 phase, 50 Hz  
Approximate Weight (318 Oven with Legs): Installed - 96 Lbs (44 kg), Shipping - 130 Lbs (59 kg)  
Dimensions: Width: 60" (152.4 cm)  
Depth: 24 7/8" (63.2 cm)  
Height: 16 1/8" (40 cm) - Single Oven with Legs

---

## GENERAL INSTALLATION DATA



### CAUTION

This equipment is designed and sold for commercial use only by personnel trained and experienced in its operation and is not sold for consumer use in and around the home nor for use directly by the general public in food service locations.

Before using your new equipment, read and understand all the instructions & labels associated with the unit prior to putting it into operation. Make sure all people associated with its use understand the units operation & safety before they use the unit.

All shipping containers should be checked for freight damage both visible and concealed. This unit has been tested and carefully packaged to insure delivery of your unit in perfect condition. If equipment is received in damaged condition, either apparent or concealed, a claim must be made with the delivering carrier.

Concealed damage or loss - if damage or loss is not apparent until after equipment is unpacked, a request for inspection of concealed damage must be made with carrier within 15 days. Be certain to retain all contents plus external and internal packaging materials for inspection. The carrier will make an inspection and will supply necessary claim forms.

## INSPECTION & ASSEMBLY

### UNCRATING AND INSPECTING

Unpack the unit and components from the shipping container. Remove all visible packing material and those from inside the cooking chamber. If damage is discovered, file a claim immediately with the carrier that handled the shipment. Do not operate the unit if it was damaged during shipping.

The following should be included: Proveyor Multi-Purpose Oven, Stainless Steel Load Up & Unload Trays, 4 Stainless Steel Legs.



### CAUTION

**REMOVE ALL HEATING ELEMENT SHIPPING SUPPORTS PRIOR TO PLACING YOUR UNIT INTO OPERATION.**

## ASSEMBLY AND INSTALLATION

The unit was shipped with certain assembly required, plug into a standard outlet specified for its voltage and amp draw. If improper electrical supply is determined, contact a qualified electrician prior to using the unit. Removal and replacement of the power cord and plug will void the warranty. For assistance, contact your local authorized service agent for service or required maintenance.

Attach the 4 legs by screwing them into the weld nuts located on the bottom of the unit. When complete, use two people to carefully turn the unit upright. Level unit by adjusting the feet (approximately 1/2" adjustment). Never operate unit without proper legs in place.

Before using the unit for the first time, wipe down the exterior with a damp cloth.



### CAUTION

Allow enough space around the oven for adequate ventilation. Do not operate the unit without the crumb tray properly positioned. Overheating and poor baking may occur. Read all labels on the unit and follow their instructions.

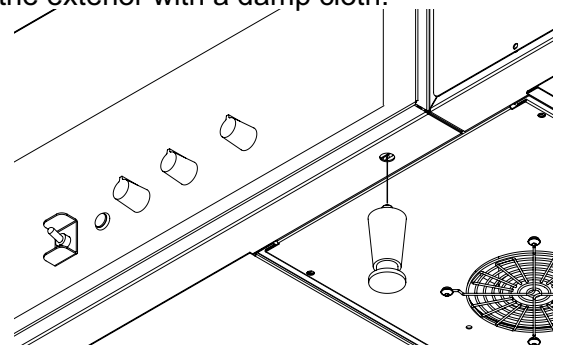

LEG INSTALLATION

## ASSEMBLY AND INSTALLATION continued

Install unit in its operating position allow sufficient space for operating personnel. Install the Load, Unload and Crumb Trays as shown, making sure the ends are at least 6" from any vertical combustible surfaces.

Have an electrician connect input power to the unit(s) in accordance with local electrical codes. A connection terminal block is inside the left side cavity for models not provided with a cord and plug set.

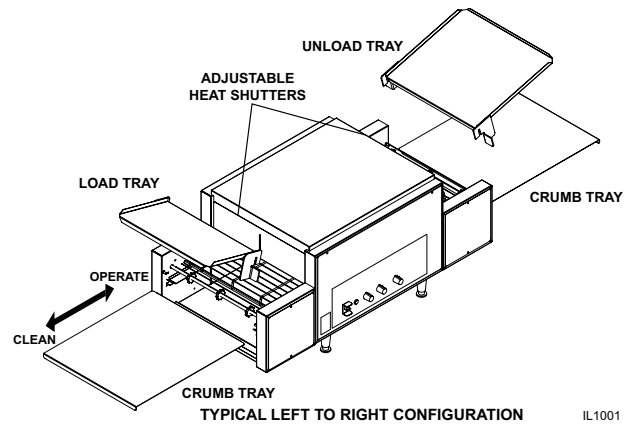

## HEATING ELEMENTS

Inspect all heating elements in the unit for breakage. Every unit is properly tested prior to leaving the factory, but damage may have occurred during shipping. If a broken tube is found, do not apply power to the unit. If everything checks out, Turn on Main Power Switch, Turn both heat controls and conveyor belt speed control to the maximum setting and check all heater tubes and conveyor for proper operation.

## COOLING SYSTEM



After the unit is initially turned on, allow 5 to 8 minutes for the fan cooling system to come on. Once on, check the air intake area located under the unit and be sure that there is a sufficient flow of air into the control box. Keep area under the unit clean from obstructions that may result in restricted air flow to the control box. Restricting the air flow will cause the unit to run hotter than designed, causing the Hi-Limit to turn unit off. See the Oven Components section on page 7 for control box & Hi-Limit Reset locations.

## FINAL CHECK

If all heaters and conveyor systems are operating properly, switch the master on/off switch to the OFF position and allow unit to cool, the fan will continue to circulate air, cooling the unit until the internal temperatures have been decreased.

If a problem is discovered during any of these start-up procedures, immediately switch the master on/off switch to the **OFF** position and notify the Star Service Department at 1-800-807-9054.



## ELECTRICAL CONNECTION

### WARNING

Before making any electrical connection to this unit, check that the power supply is adequate for the voltage, amperage and requirements stated on the rating plate. A wiring diagram is included herewith.

Disconnect the unit from the power source before installing or removing any parts.

Be absolutely sure that the ground connection for the receptacle is properly wired. Do not connect equipment to power without proper ground connections. Improper grounding may result in personal injury or fatality.



### WARNING

**DO NOT CUT OR REMOVE THIS PLUG OR GROUNDING PRONG FROM THE PLUG.**



**CONNECT/PLUG UNIT INTO DEDICATED A.C. LINE ONLY SPECIFIED ON THE DATA PLATE OF THE UNIT.**

## STACKING OVENS

When stacking two Holman Proveyor Ovens a stacking spacer with an external air duct **MUST** be used to prevent overheating of the control box of the top oven.

1. If a cart is to be used with units, place bottom unit on cart and align leg holes of unit with the holes on the cart. Insert 3/8" bolts through cart and into leg holes to secure bottom unit to cart as shown below.
2. Place stacking spacer on top of bottom oven with internal air duct facing up and towards the rear of the oven.
3. Mount external air duct on stacking spacer as shown below. External air duct must be installed for cooling system of top unit to function properly.
4. Screw cap screws (Qty 4) into leg hold on the top oven.
5. Place top oven on stacking spacer. Cap screws will set into cut out in top of stacking spacer to lock unit into position.

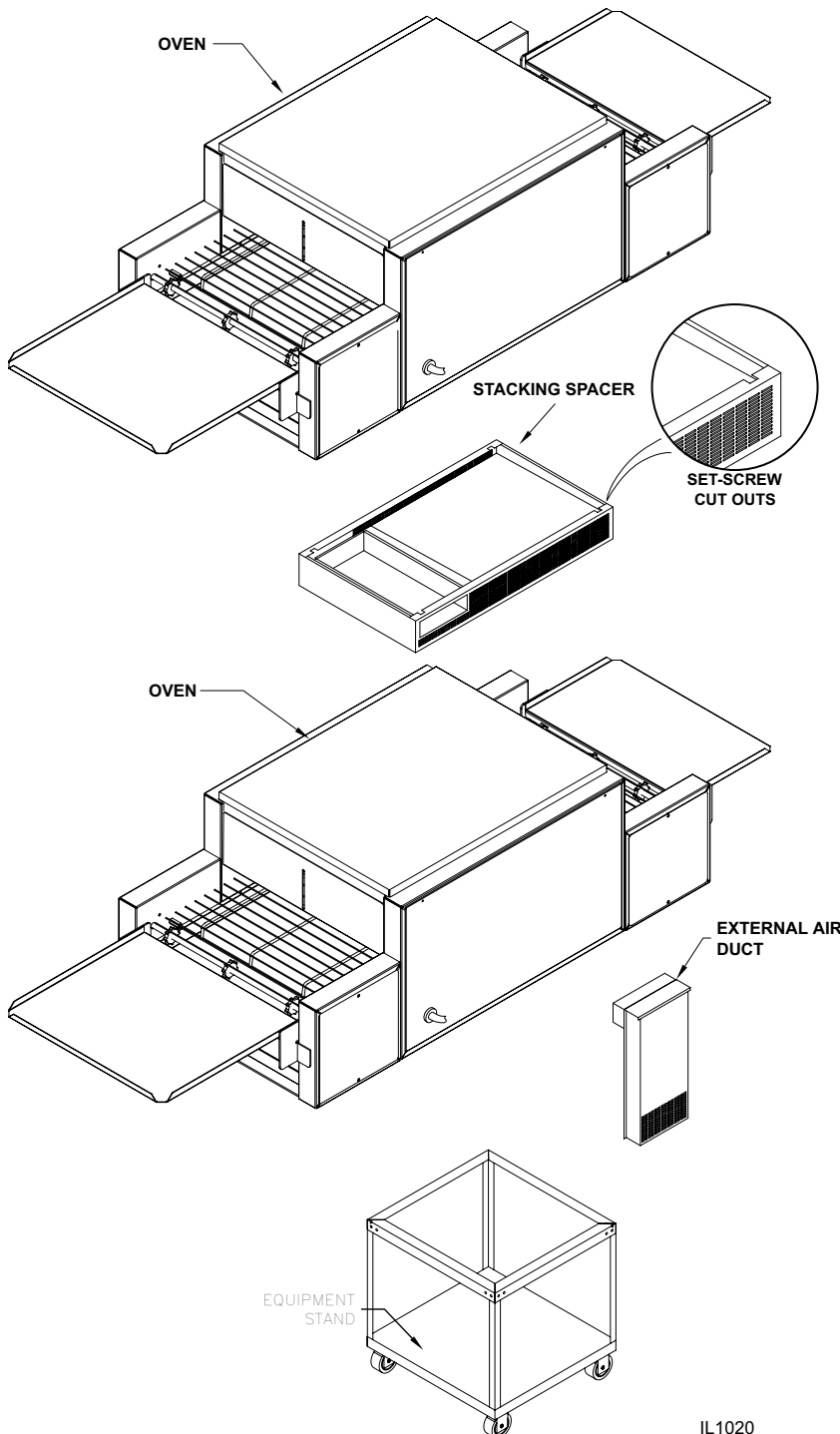

**NOTE:** Air intake of top unit must fit over the internal air duct of stacking spacer to allow airflow into the control box of the top oven.

**TOP UNIT:** cap screw, screws into leg holes, unit sits on top of spacer.

**STACKING SPACER:** (REQUIRED) Sits on top of bottom oven.

**EXTERNAL AIR DUCT:** Mounts onto spacer, pointing downward.

**BOTTOM UNIT:** Can be placed on a counter or mounted on cart as shown.

**Cart:** Mounting bolts for bottom unit screw into leg holes through the top cart frame.

## DAILY OPERATION

Baking in these units is a combination of heat and belt speed. Some foods may require more top heat or visa versa; other foods may require low top and bottom heat and slow belt speeds. Every product should, therefore, be tested using the separate top & bottom controls and the variable speed control to arrive at the correct balance of heat and belt speed. When changing heat and or belt speed setting allow approx. 5 minutes for the oven to stabilize itself at the new settings.

Check the power cord to insure that it is plugged into a proper outlet.

Always allow 10 to 15 minutes of preheat time before loading the unit with product. Failure to allow sufficient preheat time will result in unsatisfactory cooking until the unit reaches operating temperature.

- 1) Turn the master on/off switch to the ON position.
- 2) Set both the top and bottom heat controls to 500°F (260°C).  
*3-Phase Control Units, set front heat controls to 500°F (260°C)*
- 3) Turn conveyor speed control to the fastest setting.
- 4) Allow 10 to 15 minutes for initial warm up,  
(5 to 8 minutes to reach adjusted temperature, once unit is fully warmed up)



### CAUTION

**CERTAIN SURFACES ARE EXTREMELY HOT DURING OPERATION AND CARE SHOULD BE TAKEN WHILE USING THIS UNIT.**

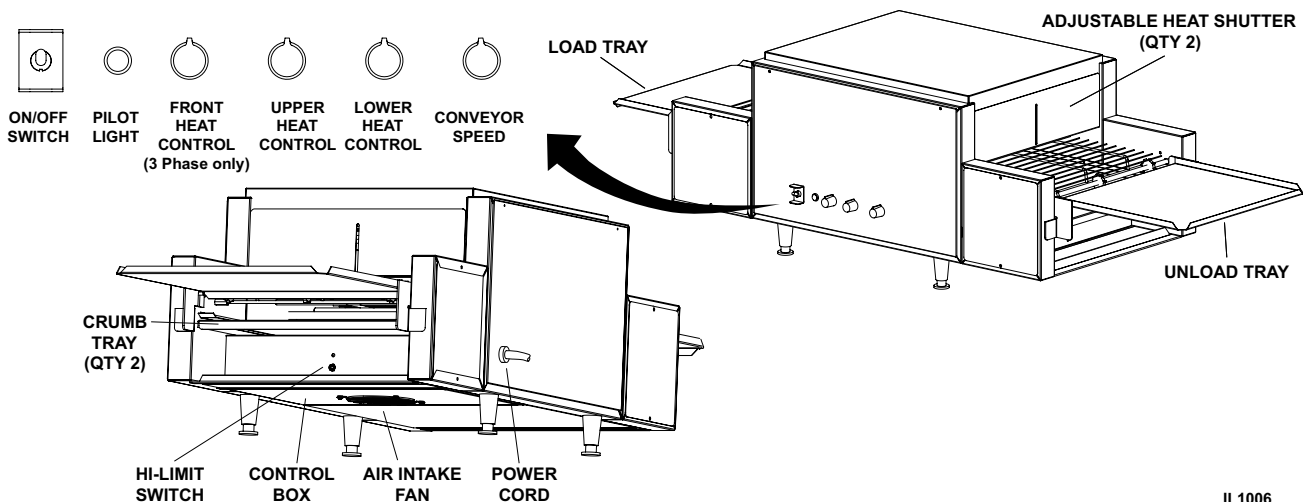

IL1006

## OVEN COMPONENTS

### OPERATING HINTS AND SAFETY

Disconnect power to the unit with the switch at the end of each day of operation.

Do not leave the unit in operation without an attendant.

Do not leave the unit at high temperature when not in use or during idle periods. This will cause food particles and grease film to carbonize. It will take only a few minutes to regain operating temperature.

## CLEANING

Preventive maintenance for your Holman Oven consists of the following recommended cleaning procedures. To keep your oven in its top operating condition, these steps should be performed on a daily, weekly or as indicated.



### WARNING

**DISCONNECT UNIT FROM POWER SUPPLY OR TURN POWER OFF AT WALL BREAKER.**

### DAILY

1. Turn main power switch to the OFF position. Disconnect unit from power source and allow to cool.
2. Using a mild detergent, wipe exterior surfaces, clean with a damp cloth.
  - a. For lightly soiled build-up, clean with a damp cloth.
  - b. For heavily soiled build-up, use an soft damp cloth and mild detergent.**DO NOT use caustic cleaners.**
3. Remove the load & unload tray by lifting them out of position. Clean using mild detergent and warm water.
4. Remove each crumb tray by sliding each of them out from under the conveyor belt. Clean crumb trays by wiping with a damp cloth and mild detergent.**DO NOT use caustic cleaners.** Place trays back in place prior to putting unit back into operation.
5. Reconnect power.



### WEEKLY

1. Turn main Power switch to the OFF position. Disconnect unit from power source and allow to cool.
2. Perform daily cleaning procedures.
3. Using a damp cloth, wipe clean the fan guard located on the control box cover under the unit.

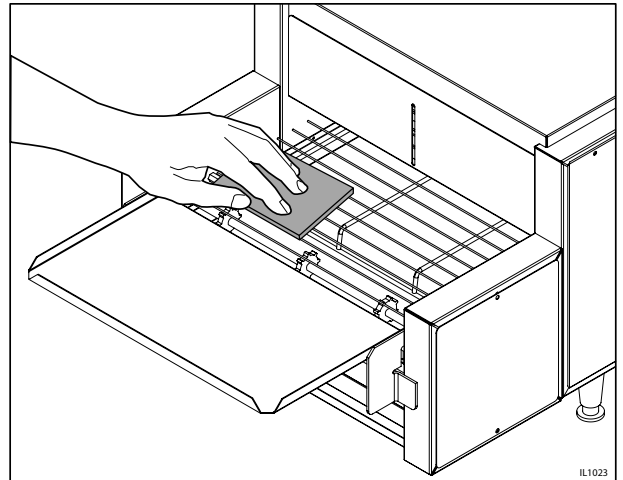

### CLEAN CONVEYOR BELT

4. Reconnect power or turn power back on.
5. Switch the ON/OFF switch to the ON position, and turn Conveyor to its fastest setting.
6. With the Conveyor turned on and the crumb trays in place, take a wire grill brush or dry abrasive pad, clean the exposed surface of Conveyor Belt by passing the brush or pad, back and forth across the surface of the Conveyor Belt as the belt moves past. Continue until the entire belt is clean. Make sure the Crumb Tray is installed, this will minimize the amount of particles that fall into the oven.
7. When the Conveyor Belt is clean, take a damp cloth and wipe the conveyor, removing any loose particles on the belt surface. Turn Conveyor OFF.
8. Remove the Crumb Trays by sliding out from beneath the conveyor belt. Clean the Crumb Trays by wiping with a damp cloth and mild detergent.**DO NOT use caustic cleaners.**  
**DO NOT RUN CONVEYOR OVEN WITHOUT CRUMB TRAYS INSTALLED.**



## CLEANING CONTINUED



### WARNING

**DO NOT IMMERSE OR LET THE UNIT STAND IN WATER.**

**DO NOT HOSE DOWN THE UNIT OR THE TABLE/COUNTER IF THE UNIT IS ON THE TABLE/COUNTER.**

**KEEP AWAY FROM RUNNING WATER.**

### MONTHLY

1. Turn main power switch to the OFF position. Disconnect unit from power source and allow to cool.
2. Perform daily & weekly cleaning procedures.

### REMOVAL & CLEANING CONVEYOR BELT

3. Heavily soiled conveyor surfaces, locate the Master Links on the conveyor belt. Follow the step 1 in Fig 1, to remove all of the Master Links. 314 models have 3 master links, 318 models have 4 master links.

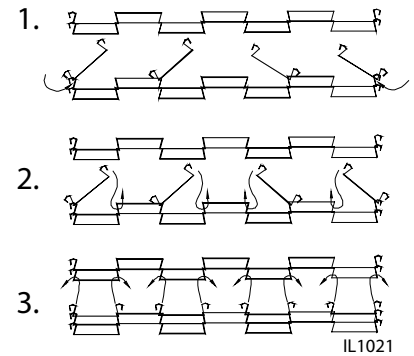

Fig 1. Master Links Removal & Installation

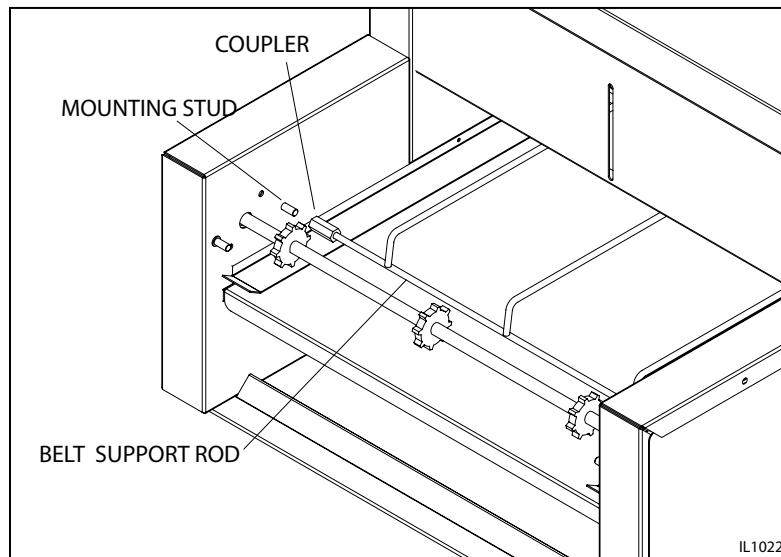

Fig 2. Removal of the Belt Support Rod

4. Now that the links have been un-hooked, the conveyor can now be carefully removed from the oven. Standing at one end of the oven. Starting with the end on the bottom, roll the conveyor belt until it has been totally removed. Take careful notice being sure not to damage the heater tubes.
5. Clean conveyor belt in deep sink, caustic cleaners may be used. For a heavy soiled conveyor belt, soak over night in hot soapy water.

### NOTE: DO NOT ATTEMPT TO CLEAN THE HEATER TUBES.

6. Take this opportunity to clean and remove any loose materials inside the unit. Using a mild cleaner and damp cloth, carefully wipe the inside surfaces being sure NOT to clean the heater tubes.

**DAMAGE CAN OCCUR TO THE HEATER TUBES FROM IMPROPER CLEANING.**

**DO NOT SPRAY CLEANING SOLUTIONS INTO OVEN CAVITY.**



## **CLEANING CONTINUED**

7. Remove the conveyor support system as shown in Fig 2. by removing the Couplers from the mounting Studs. Clean by warm water and abrasive pad.
8. Reinstall the conveyor support system.
9. Reinstall conveyor belt by first laying the belt along the bottom of the oven cavity making sure the hooks on the sides are facing the inside and the ends of the hooks will be pointing away from the direction of the belt so not to catch on any internal components once put back into operation.

### **NOTE: THE DIRECTION OF THE BELT.**

10. Next, pull one end of the conveyor belt over the top of the sprockets, (being sure to line the links up properly with the sprockets) bringing the two ends together.
11. Reinstall the previously removed master links as shown in steps 2 & 3 in Fig. 1.
12. Examine the oven to assure proper installation, once satisfied, install crumb trays if you have not done so.
13. Reconnect oven to power supply and check for proper operation.

**IF ASSISTANCE IS REQUIRED, CALL THE STAR SERVICE TEAM AT 1-800-807-9054.**

## MAINTENANCE PROCEDURES

### A. REPLACING HEATER TUBES

- 1) **DISCONNECT POWER SOURCE.**
- 2) Remove both the left and right side panels, by removing the truss head screws. Pull the top of each panel out slightly and lift up.
- 3) Remove heater tube wires which are requiring replacement from its terminal block connection.
- 4) Remove heater tube retainer by removing retainer screws with washer.
- 5) Gently, pull defective heater tube out of unit.
- 6) Gently, put new heater tube into unit.
- 7) Replace heater tube retainers.
- 8) Reconnect the heater tube wires to the terminal block.
- 9) Install each side panel
- 10) Connect unit to power source and test unit for proper operation.

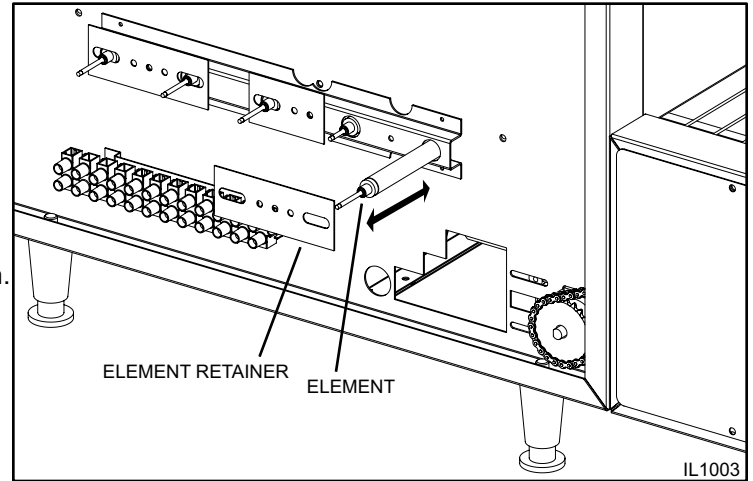

### B. REPLACING FAN MOTOR

- 1) **DISCONNECT POWER SOURCE.**
- 2) After unit has cooled, remove the load & unload trays, and turn unit over so the bottom is facing upward.
- 3) Remove the control box cover which contains the fan motor, by removing the screws.
- 4) Unplug power supply cord from fan motor.
- 5) Remove (4) screws, which hold fan motor and grill to the control box cover and remove fan.
- 6) Once removed, clean grill and control box cover using warm soapy water.
- 7) Put replacement motor and grill in place and secure to the control box cover with screws previously removed.
- 8) Reconnect power supply cord to fan motor.
- 9) Replace back panel and enclosure. Fasten with screws removed in step 3.
- 10) Connect unit to power source and test unit for proper operation.

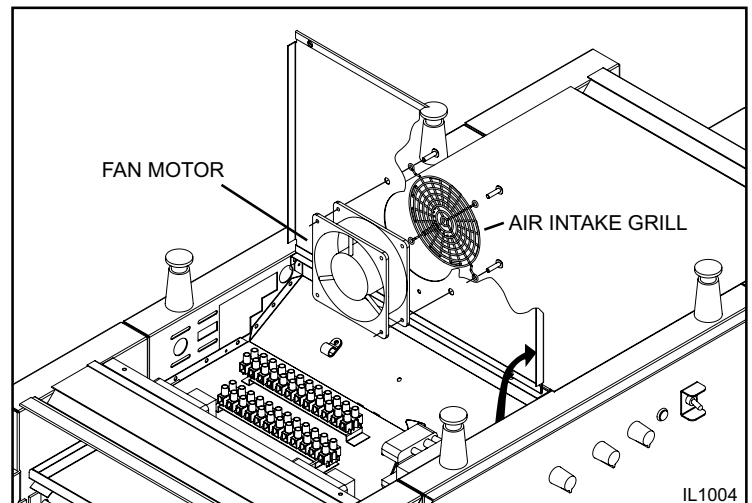

### C. REPLACING BELT DRIVE MOTOR

- 1) **DISCONNECT POWER SOURCE.**
- 2) After unit has cooled, remove the load & unload trays, and turn unit over so the bottom is facing upward.
- 3) Remove the control box cover which contains the fan motor, by removing the (4) screws.
- 4) Remove the side panel that will expose the drive chain and sprockets.
- 5) Remove sprocket from motor shaft, using an Allen wrench and loosening the set-screw.
- 6) Remove the wire from terminal block connecting the drive motor to the internal wiring.  
On units rated 208 or 240 volts, note which color leads are being used for these connections and which lead is capped with glass tape.  
The new motor should use the same arrangement.
- 7) Remove screws holding motor in place and remove motor from unit.
- 8) Put new motor in place and attach loosely with mounting screws.
- 9) Replace sprocket on motor shaft.

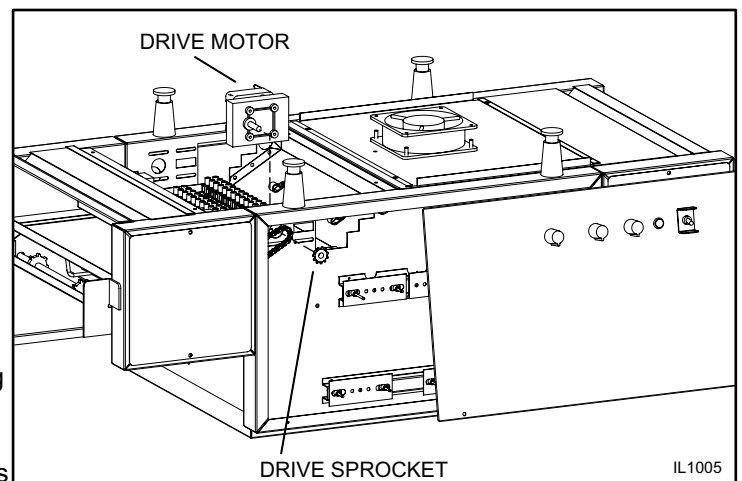

**NOTE: The two sprockets must line up FLUSH with each other, so the chain does not twist any during operation. Also the hub gets installed closest to the motor.**

## MAINTENANCE PROCEDURES continued

- 10) Slide motor until the drive chain has about 1/4" slack when lightly pushed at the center of its top open run.  
*See chain tensioning illustration.*
- 11) Tighten screws to secure motor.
- 12) Rewire leads same as removed in step 6.
- 13) At this time you may plug unit in and test for proper operation prior to reinstalling panels and turning unit back over onto its feet.
- 14) If unit is working correctly, turn unit off and unplug until completed
- 15) Reinstall side panels and control box cover.  
Place unit back into its upright position.  
Reinstall the load & unload trays.
- 16) Connect unit to power source and test unit for proper operation.

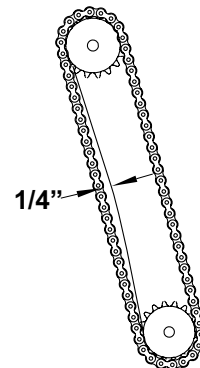

Chain Tension

### D. REPLACING SPEED CONTROL

- 1) **DISCONNECT POWER SOURCE.**
- 2) Remove the speed control knob and the locking nut holding the speed control in place.
- 3) Remove right side panel, by removing the truss head screws. Pull the top of the panel out slightly and lift up.
- 4) Wires from the speed control go into a terminal block located on the side of the chassis. Remove the wires from the control and insert wires for the new speed control into the same positions as shown on the wiring diagram.
- 5) Install the washer onto the shaft of the speed control, followed by the installation.
- 6) When mounting the speed control in the side panel be sure to position the anti-rotation pin in the slot as shown.
- 7) Tighten the speed control assembly by using the locking nut, followed by the control knob.
- 8) Reinstall the side panel and tighten with the screws previously removed.

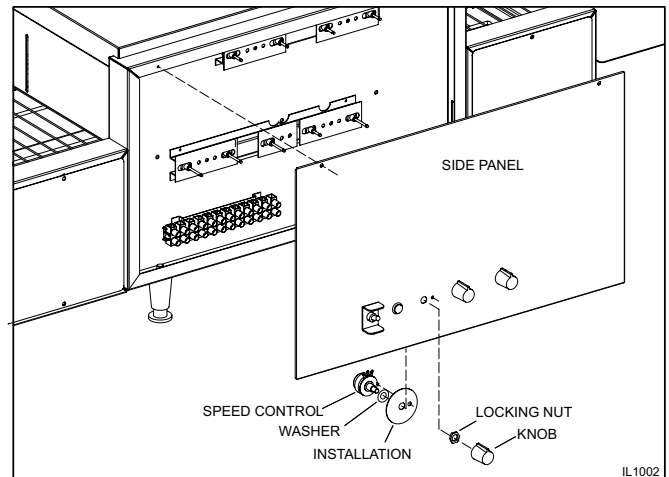

### E. CLEANING AIR INTAKE ONCE A WEEK.

- 1) **DISCONNECT UNIT FROM POWER SOURCE.**
- 2) Place unit on its backside.
- 3) Use a vacuum cleaner and or a damp cloth to clean the air intake.  
This procedure should be done at least once a week.

### F. LUBRICATE THE CHAIN & SPROCKETS EVERY 6 MONTHS

- 1) **DISCONNECT UNIT FROM POWER SOURCE.**
- 2) Remove the side panels which exposes chain drive.
- 3) Using an extreme pressure, synthetic chain lubricant with a temperature range up to 400°F. Apply liberally onto chain and sprockets.  
This grease is available separately as part no. **1P-Z8914. Call 1-(800) 807-9054 to order.**
- 4) Replace side panels, Reconnect power source and test unit.

# TROUBLESHOOTING GUIDE

## A. UNIT WILL NOT HEAT, CONVEYOR BELT WILL NOT MOVE.

- 1) Be sure the main circuit breaker is switched to the ON position and there is power to the outlet.
- 2) Check to see if the oven is plugged in and all controls are turned to the ON position.
- 3) Be sure the Hi-Limit Reset Button is pushed in.
- 4) Call the Star Service Help Desk at 1-800-807-9054.

## B. UNIT WILL NOT HEAT, CONVEYOR TURNS PROPERLY.

- 1) Check to see if the top and bottom heat controls have been turned to the maximum setting.
- 2) Press the Hi-Limit Reset Button located underneath the conveyor belt on the right side. If this reactivates the heater tubes, see Hi-Limit Reset Section below.
- 3) Call the Star Service Help Desk at 1-800-807-9054.

## C. HI-LIMIT (HEAT) RESET.

Your Holman conveyor oven is equipped with an automatic activated temperature limit switch which interrupts the heater tube connections if the air temperature in the control box exceeds 190°F (88°C) This limit switch can be reset manually by pushing the button in the center of the switch which is located on the right side under the conveyor belt. See Oven Components on Page 7 for location. Unit will not reset until internal temperature has fallen below 190°F (88°C).

**NOTE: THE HI-LIMIT SWITCH CAN BE ACTIVATED IF THERE IS NOT A PROPER AMOUNT OF AIR FLOW BEING GENERATED BY THE COOLING FAN. IF THIS OCCURS:**

- 1) DISCONNECT UNIT FROM POWER SOURCE.
- 2) Check to see if the air intake area (center of the control box, bottom of unit) is free of dust, grease or other obstructions.
- 3) Check to see if crumb trays (heat reflectors) are in place. If the Hi-Limit Switch can not be reset, call the Star Service Help Desk at 1-800-807-9054.



## CAUTION

**NEVER OPERATE UNIT WITHOUT CRUMB TRAYS IN POSITION AS THIS CAUSES OVERHEATING IN THE CONTROL BOX.**

## D. CONVEYOR WILL NOT TURN, UNIT HEATS PROPERLY.

To check for mechanical binding:

- 1) **DISCONNECT UNIT FROM POWER SOURCE.**
- 2) Check to see if there are obstructions in the conveyor system that may cause a jam. If so, remove obstruction.
- 3) Check power supply & terminal blocks for loose or disconnected wires.
- 4) Remove right side panel and drive motor sprockets, see illustration. Manually move conveyor belt to check for mechanical binding. If conveyor belt moves freely, call the Star Service Help Desk at 1-800-807-9054.  
The drive motor or speed control may have to be replaced.

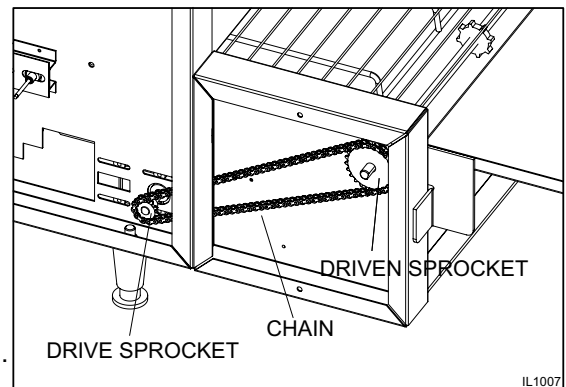

## E. CONVEYOR TURNS AT ONE SPEED REGARDLESS OF SPEED CONTROL SETTING.

- 1) Call the Star Service Help Desk at 1-800-807-9054, as speed control **MAY** need replacing.  
Refer to **REPLACING SPEED CONTROL** in the previous section.

## F. COOLING FAN DOES NOT START

- 1) Remove control box cover and check fan blade for obstruction.
- 2) Check electrical connections are secure and complete.
- 3) Call the Star Service Help Desk at 1-800-807-9054, as the fan switch and or fan motor **MAY** need replacing.  
Refer to **REPLACING FAN MOTOR** in the previous section.

### THOROUGHLY INSPECT YOUR UNIT ON ARRIVAL

This unit has been tested for proper operation before leaving our plant to insure delivery of your unit in perfect condition. However, there are instances which the unit may be damaged in transit. In the event you discover any type of damage to your product upon receipt, you must immediately contact the transportation company who delivered the item to you and initiate your claim with same. If this procedure is not followed, it may affect the warranty status of the unit.

### LIMITED EQUIPMENT WARRANTY

All workmanship and material in Star products have a one (1) year limited warranty on parts & labor in the United States and Canada. Such warranty is limited to the original purchaser only and shall be effective from the date the equipment is placed in service. Star's obligation under this warranty is limited to the repair of defects without charge, by the factory authorized service agency or one of its sub-agencies. Models that are considered portable (*see below*) should be taken to the closest Star service agency, transportation prepaid.

- > Star will not assume any responsibility for loss of revenue.
- > On all shipments outside the United States and Canada, see International Warranty.
- \* The warranty period for the JetStar series six (6) ounce popcorn machines is two (2) years.
- \* The warranty period for the Chrome-Max Griddles is five (5) years on the griddle surface. See detailed warranty provided with unit.
- \* The warranty period for Teflon/Dura-Tec coatings is one year under normal use and reasonable care. This warranty does not apply if damage occurs to Teflon/Dura-Tec coatings from improper cleaning, maintenance, use of metallic utensils, or abrasive cleaners. This warranty does not apply to the "non-stick" properties of such materials.
- > This warranty does not apply to "Special Products" but to regular catalog items only. Star's warranty on "Special Products" is six (6) months on parts and ninety (90) days on labor.
- > This warranty does not apply to any item that is disassembled or tampered with for any purpose other than repair by a Star Authorized Service Center or the Service Center's sub-agency.
- > This warranty does not apply if damage occurs from improper installation, misuse, wrong voltage, wrong gas or operated contrary to the Installation Operating instructions.
- > This warranty is not valid on Conveyor Ovens *unless* a "start-up/check-out" has been performed by a Factory Authorized Technician.

### PARTS WARRANTY

Parts that are sold to repair out of warranty equipment are warranted for ninety (90) days. The part only is warranted. Labor to replace the part is chargeable to the customer.

### SERVICES NOT COVERED BY WARRANTY

- |                                                                                                                                                                      |                                                                                                 |
|----------------------------------------------------------------------------------------------------------------------------------------------------------------------|-------------------------------------------------------------------------------------------------|
| 1. Travel time and mileage rendered beyond the 50 mile radius limit                                                                                                  | 10. Voltage conversions                                                                         |
| 2. Mileage and travel time on portable equipment ( <i>see below</i> )                                                                                                | 11. Gas conversions                                                                             |
| 3. Labor to replace such items that can be replaced easily during a daily cleaning routine, ie; removable kettles on fryers, knobs, grease drawers on griddles, etc. | 12. Pilot light adjustment                                                                      |
| 4. Installation of equipment                                                                                                                                         | 13. Miscellaneous adjustments                                                                   |
| 5. Damages due to improper installation                                                                                                                              | 14. Thermostat calibration and by-pass adjustment                                               |
| 6. Damages from abuse or misuse                                                                                                                                      | 15. Resetting of circuit breakers or safety controls or reset button                            |
| 7. Operated contrary to the Operating and Installation Instructions                                                                                                  | 16. Replacement of bulbs                                                                        |
| 8. Cleaning of equipment                                                                                                                                             | 17. Replacement of fuses                                                                        |
| 9. Seasoning of griddle plates                                                                                                                                       | 18. Repair of damage created during transit, delivery, & installation OR created by acts of God |

### PORTABLE EQUIPMENT

Star will not honor service bills that include travel time and mileage charges for servicing any products considered "Portable" including items listed below. These products should be taken to the Service Agency for repair:

- \* The Model 510FD Fryer.
- \* The Model J4R, 4 oz. Popcorn Machine.
- \* The Model 518CMA & 526CMA Cheese Melter.
- \* The Model 12MC & 15MC & 18MCP Hot Food Merchandisers.
- \* The Model 12NCPW & 15NCPW Nacho Chip/Popcorn Warmer.
- \* All Hot Dog Equipment **except Roller Grills & Drawer Bun Warmers.**
- \* All Nacho Cheese Warmers **except Model 11WLA Series Nacho Cheese Warmer.**
- \* All Condiment Dispensers **except the Model HPDE, & SPDE Series Dispenser.**
- \* All Specialty Food Warmers **except Model 130R, 11RW Series, and 11WSA Series.**
- \* All QCS/RCS Series Toasters **except Model QCS3 & RCS3 Series.**

#### ALL:

- \* Pop-Up Toasters
- \* Butter Dispensers
- \* Pretzel Merchandisers
- \* Pastry Display Cabinets
- \* Nacho Chip Merchandisers
- \* Accessories of any kind
- \* Sneeze Guards
- \* Pizza Ovens
- \* Heat Lamps
- \* Pumps

The foregoing warranty is in lieu of any and all other warranties expressed or implied and constitutes the entire warranty.

### FOR ASSISTANCE

Should you need any assistance regarding the Operation or Maintenance of any Star equipment; write, phone, fax or email our Service Department. In all correspondence mention the Model number and the Serial number of your unit, and the voltage or type of gas you are using.

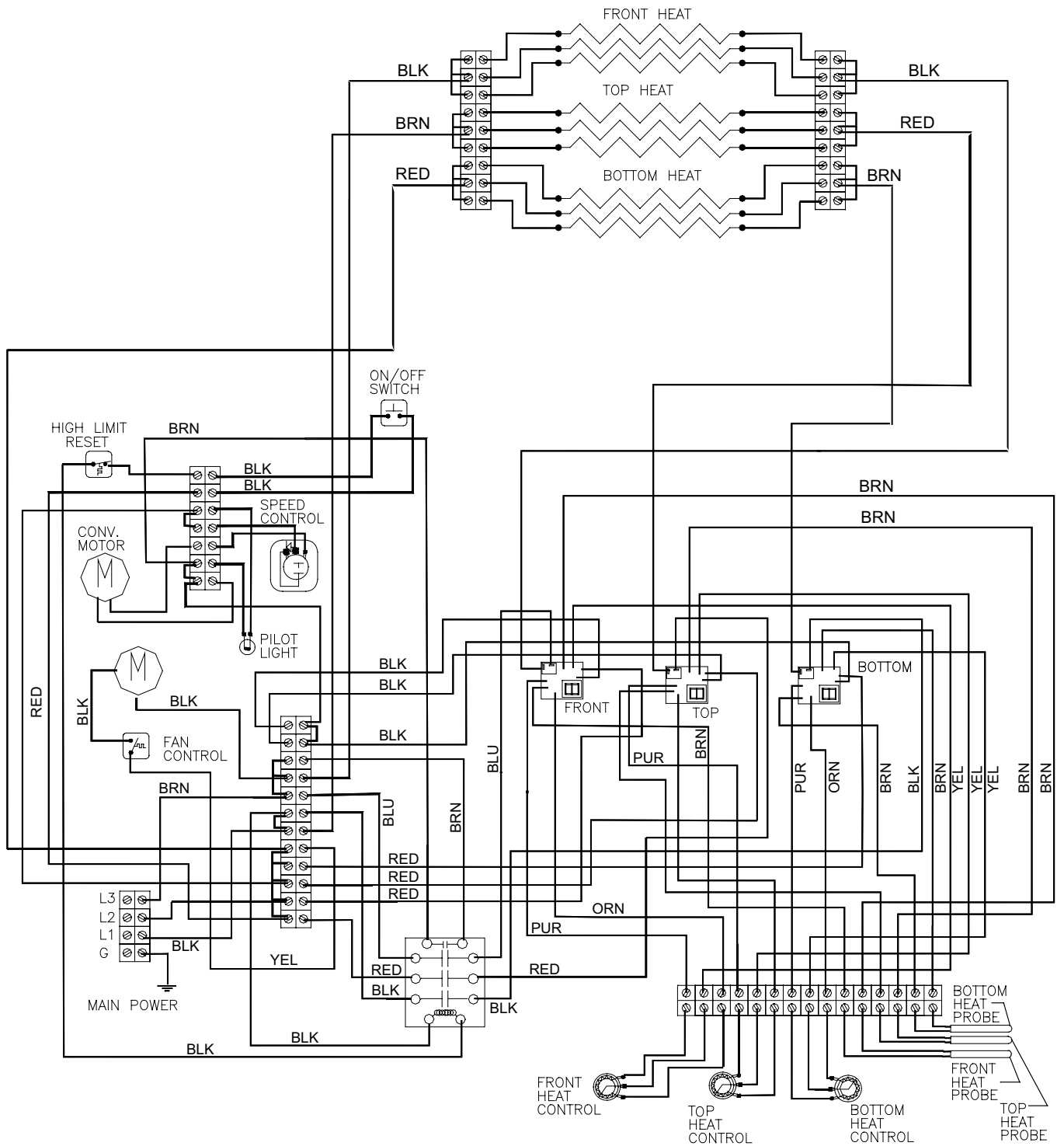

MODEL: 314HX, 318HX, 208/240V, 3 PHASE, DELTA CONF



STAR MANUFACTURING INTERNATIONAL INC.

THIS DRAWING CONTAINS INFORMATION CONFIDENTIAL TO STAR MFG. INT'L. INC.  
NO REPRODUCTION OR DISCLOSURE OF ITS CONTENTS IS PERMITTED.

820134

Rev -

03/27/2000

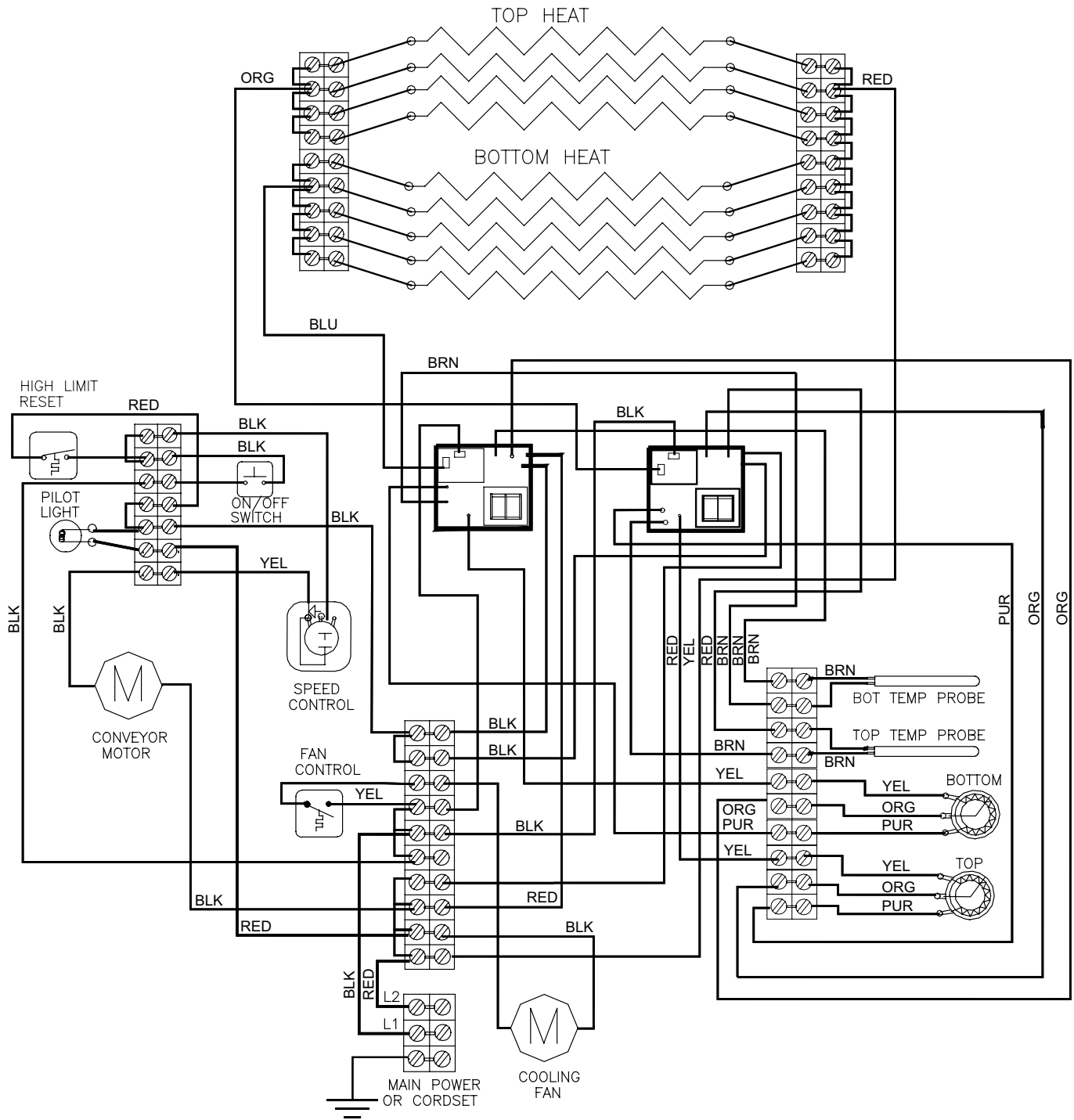

MODEL: 314HX, 318HX, 208/240V, SINGLE PHASE



STAR MANUFACTURING INTERNATIONAL INC.

THIS DRAWING CONTAINS INFORMATION CONFIDENTIAL TO STAR MFG. INT'L. INC.  
NO REPRODUCTION OR DISCLOSURE OF ITS CONTENTS IS PERMITTED.

820078

Rev A

08/16/2001



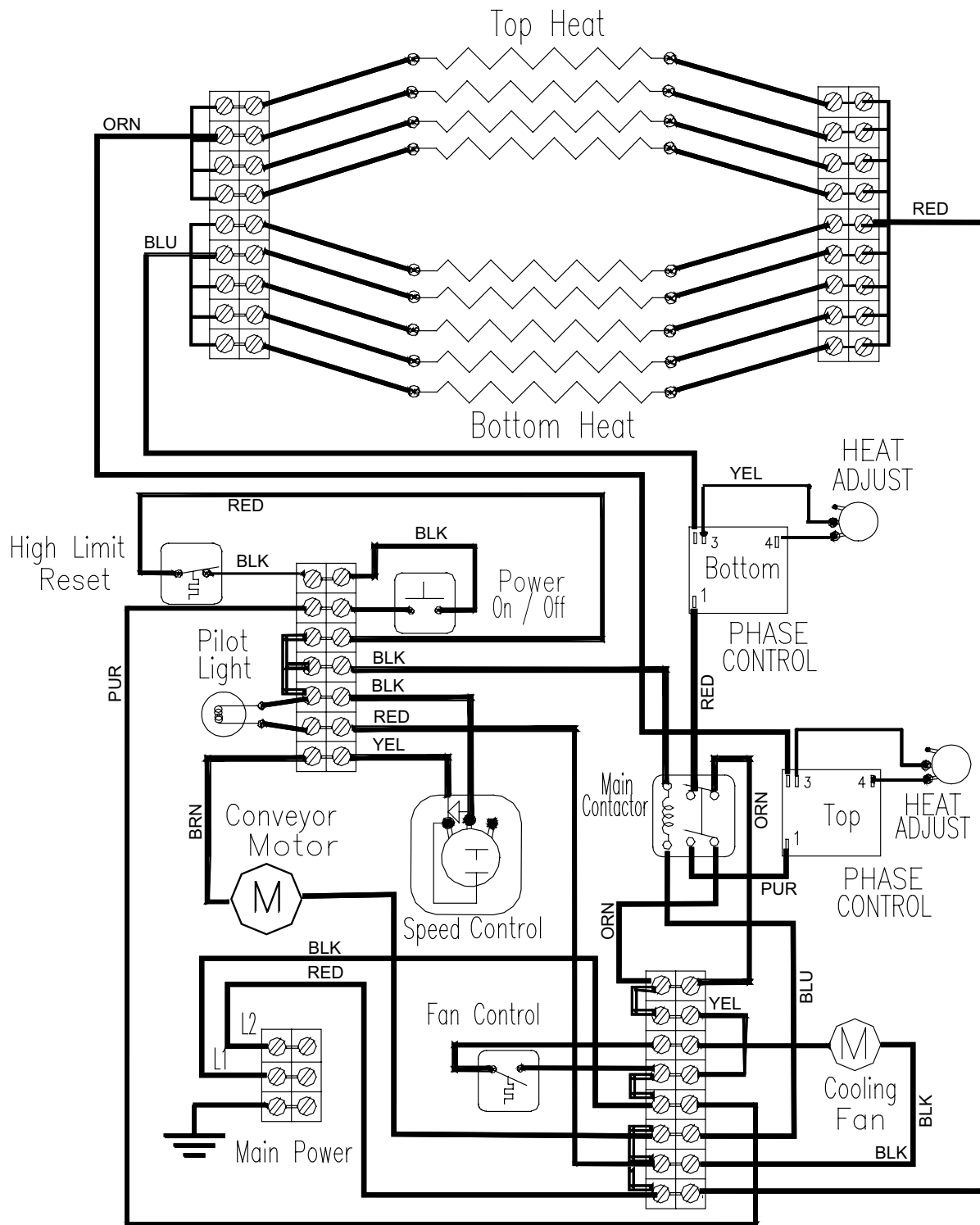

MODEL: 314HX, 318HX, 208/220/240 VOLT, 60 Hz  
 SINGLE PHASE (PHASE CONTROLS)



**STAR MANUFACTURING INTERNATIONAL INC.**

THIS DRAWING CONTAINS INFORMATION CONFIDENTIAL TO STAR MFG. INT'L. INC.  
 NO REPRODUCTION OR DISCLOSURE OF ITS CONTENTS IS PERMITTED.

020078

Rev -

05/2/2000

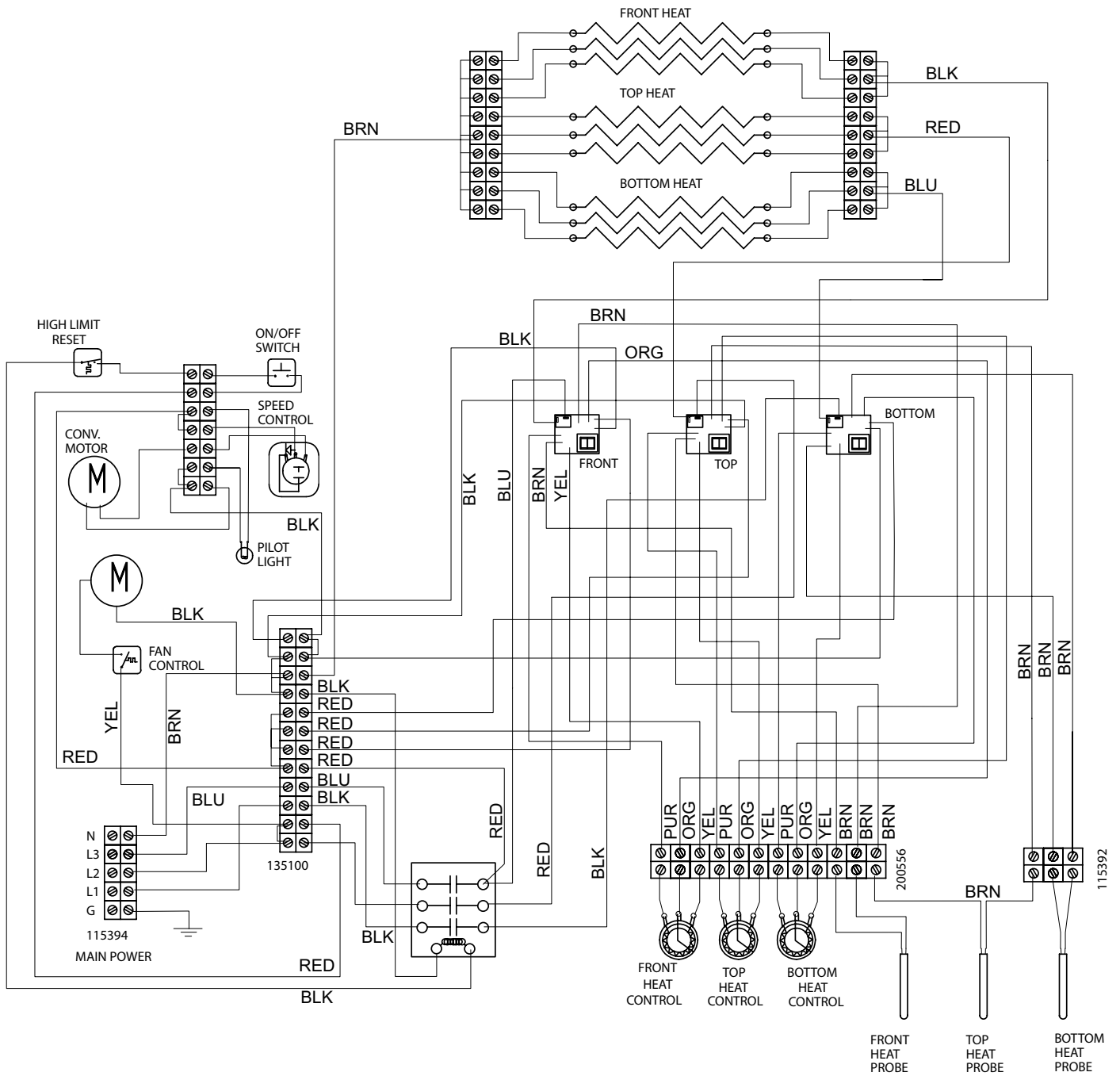

**MODEL: 314HX, 318HX, THREE PHASE WYE CONF.  
(STRATFORD CONTROLS)**



THIS DRAWING CONTAINS INFORMATION CONFIDENTIAL TO STAR MFG. INT'L. INC.  
NO REPRODUCTION OR DISCLOSURE OF ITS CONTENTS IS PERMITTED.

**STAR MANUFACTURING INTERNATIONAL INC.**

820145

Rev B

10/22/2004



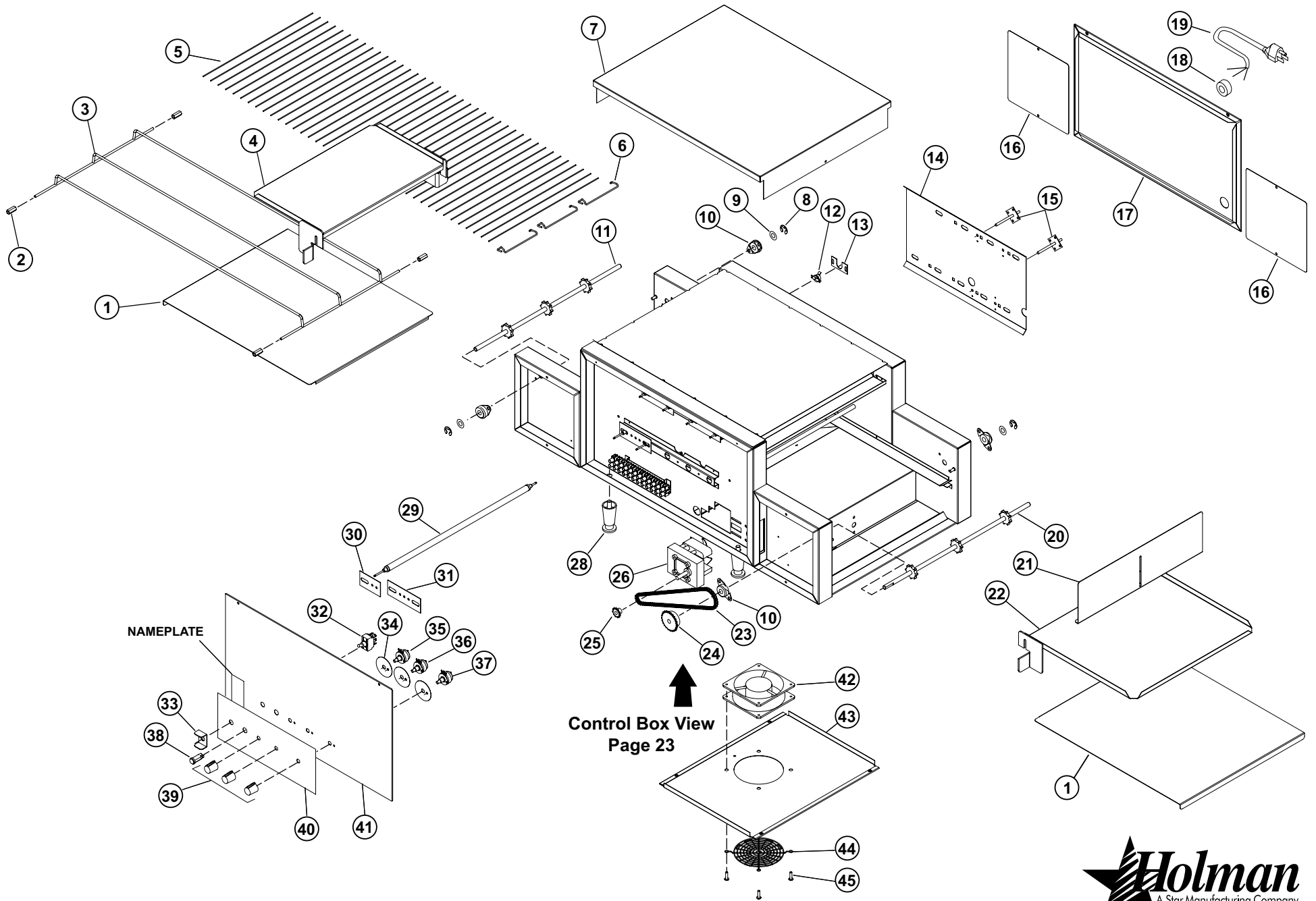

**MODEL: PROVEYOR**  
 314HX, 318HX, 418HX



SK2145 Rev. - 9/12/05



# 314HX Series Holman Conveyor Oven

Fig No.	Part Number	Quantity Per	Description	Fig No.	Part Number	Quantity Per	Description
1	GD-401227	2	TRAY, CRUMB	33	2P-401780	1	GUARD, TOGGLE
2	2A-200672	4	COLLAR, SHAFT	34	2E-200180	3	INSULATION, SWITCH, POT.
3	GD-100707	1	RACK, BELT SUPPORT SYSTEM	35	2J-200567	1	SWITCH, FRONT HEAT CONTROL POT. 3 Phase
4	GD-100403	1	TRAY, LOAD-UP	35	2J-200567	1	SWITCH, TOP HEAT CONTROL POT.
5	GD-160008	1	CONVEYOR BELT (14" X 75")	35	GD-115350	1	SWITCH, CONTROL HEAT ASSY TOP 240V/50/3PH
6	2B-200626	3	LINK, MASTER, CONVEYOR BELT	36	2J-200567	1	SWITCH, BOTTOM HEAT CONTROL POT.
7	GD-401168	1	COVER, TOP	36	GD-115351	1	SWITCH, CONTROL HEAT ASSY BOTTOM 240V/50/3PH
8	2A-200284	3	E-CLIP	37	2J-200423	1	SWITCH, SPEED CONTROL (1000Ω) 314HX
9	2C-200149	3	WASHER	38	2J-200427	1	PILOT LIGHT
10	GB-112262	4	BUSHING 3/8"	39	2R-200708	3	CAP, KNOB CONTROL
11	GD-101253	1	SHAFT, IDLER (3/8")	39	2R-200708	4	CAP, KNOB CONTROL 3 Phase
12	2E-200574	1	SWITCH, FAN MOTOR	39	2R-200768	3	KNOB, HEAT CONTROL, SPEED CONTROL
13	HG-402144	1	FAN SWITCH BRACKET	39	2R-200768	4	KNOB, HEAT CONTROL, SPEED CONTROL 3 Phase
14	GD-401238	1	RETAINER, HEATER TUBE RIGHT	40	2M-200866	1	LABEL 3 PHASE HX CONTROL LABEL 3 Phase
15	2J-200568	2	PROBE, HEAT (Stratford Control Model)	40	2M-200872	1	LABEL, CONTROL PANEL
15	2J-200568	3	PROBE, HEAT (Stratford Control Model) 3 Phase	41	GD-401375	1	PANEL, CONTROL SIDE
16	GD-401206	4	COVER, EXTENSION SIDE	41	GD-401540	1	PANEL, CONTROL SIDE 3 Phase
17	GD-401376	1	PANEL, CORD SIDE (L-R MODEL)	42	2U-200561	1	MOTOR, FAN
17	GD-401377	1	PANEL, CORD SIDE (R-L MODEL)	43	HT-401496	1	COVER, CONTROL BOX
18	2K-200458	1	BUSHING, POWER SUPPLY CORD	44	2R-200562	1	GRILL, FAN MOTOR
19	2E-200383	1	**CORD, POWER SUPPLY 314HX	45	2C-200048	4	SCREW, SLOT HEX 10-24 X 1/2
20	GD-101252	1	SHAFT, DRIVE (3/8")	46	2J-200569	2	CONTROL, HEAT (Stratford Control)
21	GD-401233	2	SHUTTER, HEAT	46	2J-200569	3	CONTROL, HEAT (3 PHASE) 3 Phase
22	GD-101403	1	TRAY, UNLOAD	47	SP-115146	1	SWITCH, HIGH LIMIT RESET
23	2P-150023	1	DRIVE CHAIN (27")	48	SP-115338	2	CONTROL, HEAT (Phase Control) 120V
24	2P-200654	1	SPROCKET, DRIVEN (25B24 X 3/8")	48	SP-115339	2	CONTROL, HEAT (Phase Control)
25	2P-200643	1	SPROCKET, DRIVE (25B11 X 5/16")	48	SP-115339	3	CONTROL, HEAT (Phase Control) 3 Phase
26	2U-200504	1	MOTOR, DRIVE (L-R)	49	2E-200529	1	CONTACTOR 3PH 3 Phase
26	2U-200508	1	MOTOR, DRIVE 3286 BB REV, 50hr	NI	2B-200624	ea.	LINK, CONVEYOR BELT
26	2U-200509	1	MOTOR, DRIVE (R-L)	NI	2E-200554	~	TERMINAL BLOCK, 12 POS. LARGE
27	2R-200721	1	BLADE, FAN, DRIVE MOTOR	NI	2J-200423	2	SWITCH, SPEED CONTROL (1000Ω) 240V/50/3PH
28	2R-200716	4	LEG, 2 1/2" METAL	NI	GB-118062	1	SPEED CONTROL, 1000 OHM
29	GD-197888	9	HEATERTUBE, QUARTZ 208V	NI	GD-115392	1	TERMINAL BLOCK, 3 POS. LARGE (Power Input)
29	GD-197893	9	HEATERTUBE, QUARTZ 220V	NI	GD-115396	~	TERMINAL BLOCK, 7 POS. LARGE
29	GD-197889	9	HEATERTUBE, QUARTZ 240V	NI	GD-115397	~	TERMINAL BLOCK, 8 POS. LARGE
29	2N-209201	9	HEATERTUBE, METAL 208V	NI	GD-115523	~	JUMPER, 4 POS. LARGE
29	HZ-114240	9	HEATERTUBE, METAL 240V	NI	GD-118060	1	SPEED CONTROL, V82, V84
30	GD-402446	1	RETAINER, SINGLE HEATERTUBE, QUARTZ	NI	HM-115398	~	TERMINAL BLOCK, 9 POS. LARGE
30	GD-401238	1	RETAINER, SINGLE HEATERTUBE, METAL	NI	HM-115521	~	JUMPER, 2 POS. LARGE
31	GD-401232	4	RETAINER, DUAL HEATERTUBES, QUARTZ	NI	HM-115522	~	JUMPER, 3 POS. LARGE
31	GG-401989	4	RETAINER, HEATERTUBES, METAL	NI	<b>1P-Z8914</b>	1	EXTREME PRESSURE MULTIPURPOSE SYNTHETIC GREASE (80°F TO 400°F) , TUBE 8 oz.
32	2E-200564	1	SWITCH, ON/OFF TOGGLE 314HX				



# 318HX Series Holman Conveyor Oven

Fig No.	Part Number	Quantity Per	Description	Fig No.	Part Number	Quantity Per	Description
1	GF-401228	2	TRAY, CRUMB	31	GD-401232	4	RETAINER, DUAL HEATERTUBES, QUARTZ
2	2A-200672	4	COLLAR, SHAFT	31	GG-401989	4	RETAINER, DUAL HEATERTUBES, METAL
3	GF-100709	1	RACK, BELT SUPPORT SYSTEM	32	2E-200564	1	SWITCH, ON/OFF TOGGLE
4	GF-100405	1	TRAY, LOAD-UP	33	2P-401780	1	GUARD, TOGGLE
5	GF-160009	1	CONVEYOR BELT (14" X 75")	34	2E-200180	3	SWITCH BARRIER, POT
6	2B-200621	4	LINK, MASTER, CONVEYOR BELT	35	2J-200567	1	SWITCH, FRONT HEAT CONTROL POT. 3 Phase
7	GF-401167	1	COVER, TOP	35	2J-200567	1	SWITCH, TOP HEAT CONTROL POT.
8	2A-200284	3	E-CLIP	36	2J-200567	1	SWITCH, BOTTOM HEAT CONTROL POT.
9	2C-200149	3	WASHER	37	GB-118062	1	SWITCH, SPEED CONTROL (1000Ω)
10	GB-112262	4	BUSHING 3/8"	38	2J-200427	1	PILOT LIGHT
11	2A-100923	1	ROD IDLER	39	2R-200708	3	CAP, KNOB CONTROL
11	2P-200642	4	SPROCKET IDLER	39	2R-200708	4	CAP, KNOB CONTROL 3 Phase
12	2E-200574	1	SWITCH, FAN MOTOR	39	2R-200768	3	KNOB, HEAT CONTROL, SPEED CONTROL
13	HG-402144	1	BRACKET, FAN SWITCH	39	2R-200768	4	KNOB, HEAT CONTROL, SPEED CONTROL 3 Phase
14	GD-401238	1	RETAINER, HEATER TUBE, RIGHT	40	2M-200866	1	LABEL, CONTROL PANEL 3 Phase
15	2J-200568	2	PROBE, HEAT (Stratford Control Model)	40	2M-200872	1	LABEL, CONTROL PANEL
15	2J-200568	3	PROBE, HEAT (Stratford Control Model) 3 Phase	41	GD-401375	1	PANEL, CONTROL SIDE
16	GD-401206	4	COVER, EXTENSION SIDE	41	GD-40150	1	PANEL, CONTROL SIDE 3 Phase
17	GD-401376	1	PANEL, CORD SIDE (L-R MODEL)	42	2U-200561	1	MOTOR, FAN
17	GD-401377	1	PANEL, CORD SIDE (R-L MODEL)	43	GF-402818	1	COVER, CONTROL BOX
18	2K-200458	1	BUSHING, POWER SUPPLY CORD	44	2R-200562	1	GRILL, FAN MOTOR
19	2E-200383	1	**CORD, POWER SUPPLY	45	2C-200048	4	SCREW, SLOT HEX 10-24 X 1/2"
20	2A-100922	1	ROD DRIVE	46	SP-115347	2	CONTROL, HEAT (Stratford Control)
20	2P-200642	4	SPROCKET, DRIVE SHAFT	46	SP-115347	3	CONTROL, HEAT (Stratford Control) 3 Phase
21	GF-401289	2	SHUTTER, HEAT	47	2E-200566	1	SWITCH, HIGH LIMIT RESET
22	GF-101404	1	TRAY, UNLOAD	48	SP-115339	2	CONTROL, HEAT (Phase Control)
23	2P-150023	1	DRIVE CHAIN (27")	48	SP-115339	3	CONTROL, HEAT (Phase Control) 3 Phase
24	2P-200654	1	SPROCKET, DRIVEN (25B24 X 3/8")	49	2E-200529	1	CONTACTOR 3 Phase
25	2P-200643	1	SPROCKET, DRIVE (25B11 X 5/16")	NI	GD-115392	1	TERMINAL BLOCK, 3 POS, LARGE (Power Input)
26	2U-200504	1	MOTOR, DRIVE (L-R)	NI	GD-115396	1	TERMINAL BLOCK, 7 POS. LARGE
26	2U-200509	1	MOTOR, DRIVE (R-L)	NI	GD-115397	-	TERMINAL BLOCK, 8 POS, LARGE
26	2U-200508	1	MOTOR, DRIVE 3286 BB REV, 50hr	NI	HM-115398	2	TERMINAL BLOCK, 9 POS. LARGE
27	2R-200721	1	BLADE, FAN, DRIVE MOTOR	NI	2E-200554	5	TERMINAL BLOCK, 12 POS. LARGE
28	2R-200716	4	LEG, 2 1/2" METAL	NI	2P-115222	1	JUMPER, 3 POS. LARGE
29	GF-197885	9	HEATERTUBE QUARTZ 208V	NI	2P-115521	3	JUMPER, 2 POS. LARGE
29	GF-197891	9	HEATERTUBE QUARTZ 220V	NI	GD-115523	2	JUMPER, 4 POS. LARGE
29	GF-197886	9	HEATERTUBE QUARTZ 240V	NI	GD-115524	1	JUMPER, 5 POS. LARGE
29	GG-114250	9	HEATERTUBE, METAL 690W 208V	NI	GD-115528	1	JUMPER, 9 POS. LARGE
29	2N-209205	9	HEATERTUBE, METAL 688W 208V	NI	1P-Z8914	1	EXTREME PRESSURE MULTIPURPOSE SYNTHETIC GREASE (80°F TO 400°F) , TUBE 8 oz.
29	2N-209207	9	HEATERTUBE, METAL 688W 240V				
30	GD-402446	1	RETAINER, SINGLE HEATERTUBE, QUARTZ				
30	GD-401238	1	RETAINER, SINGLE HEATERTUBE, METAL				

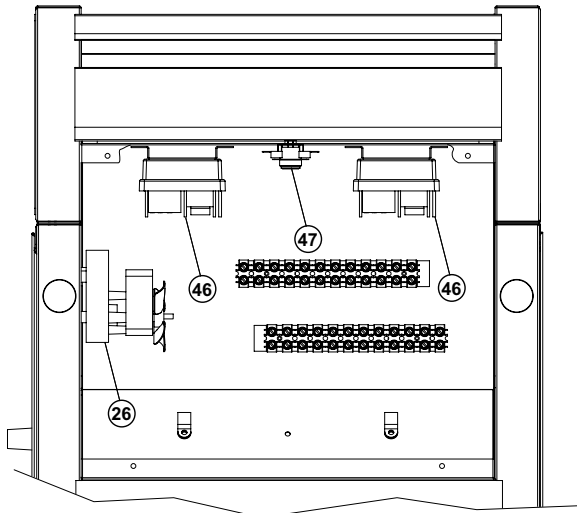

**314 Stratford Control**  
Left to Right Conveyor

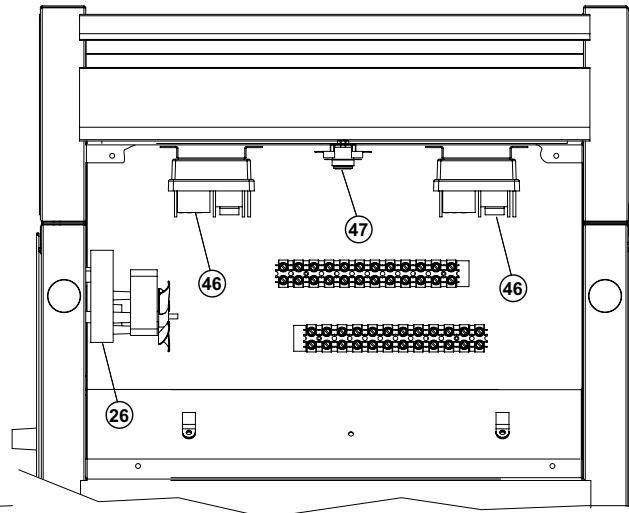

**318 Stratford Control**  
Left to Right Conveyor

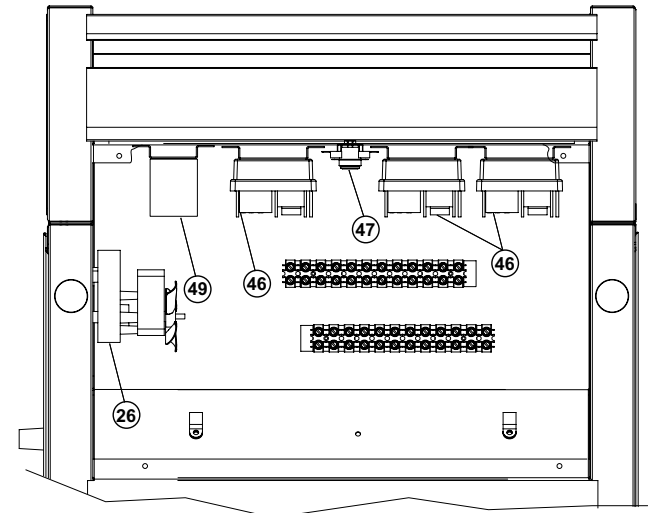

**318 Stratford Control 3 Phase**  
Left to Right Conveyor

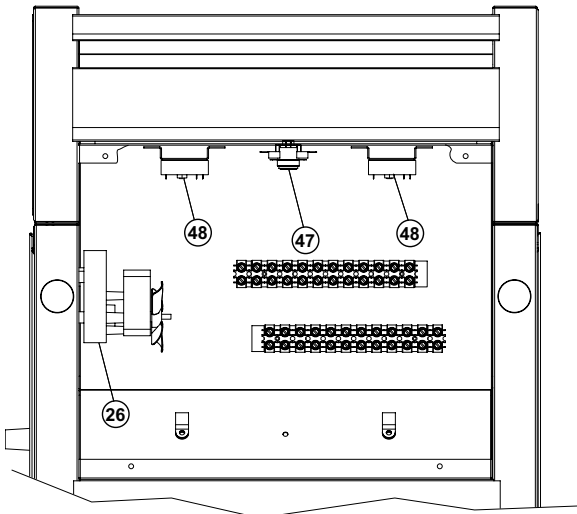

**314 Phase Control**  
Left to Right Conveyor

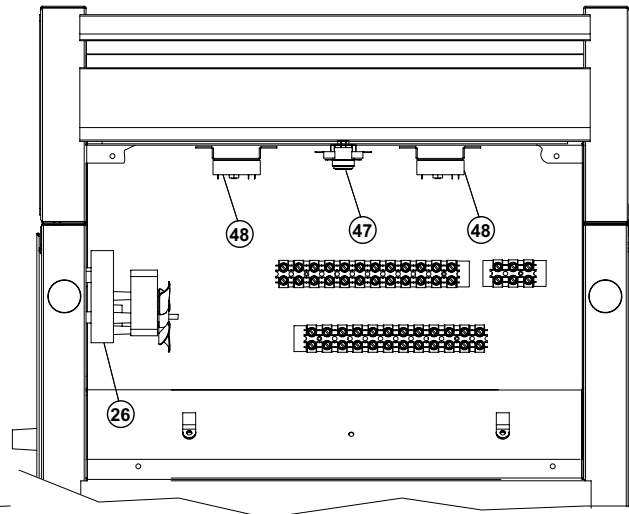

**318 Phase Control**  
Left to Right Conveyor

**MODEL: PROVEYOR CONTROL BOX CONFIGURATION**



SK2146

Rev. - 9/12/05

**STAR MANUFACTURING**

10 Sunnen Drive, St. Louis, MO 63143 U.S.A.

(800) 807-9054 (314) 781-2777

Parts & Service (800) 807-9054

[www.star-mfg.com](http://www.star-mfg.com)